

# TOP-0110

*Control unit with dimmer function for wired or radio control of devices with 0-10 V / 1-10 V input. 110-240 Vac power supply, max power 2000 W. Integrated radio receiver 433.92 MHz.*

**NEXTA**  
T E C H



---

## INDEX

### 1 - PRODUCT FEATURES

- 1.1 - TECHNICAL DATA
- 1.2 - DESCRIPTION

### 2 - ELECTRICAL CONNECTION

- 2.1 - CONNECTION DIAGRAM
- 2.2 - DESCRIPTION OF CONNECTIONS

### 3 - USE OF THE CONTROL UNIT

- 3.1 - USE VIA RADIO
- 3.2 - USE VIA WIRE

### 4 - CONTROL UNIT SETTINGS

- 4.0 - SELECTION OF TYPE OF LOAD CONNECTED: "0-10V" OR "1-10V"
- 4.1 - RADIO PROGRAMMING OF MULTIFUNCTIONAL AND GENERIC TRANSMITTERS
- 4.2 - DELETION OF RADIO
- 4.3 - "SAVE" FUNCTION (BRIGHTNESS LEVEL AT SWITCH-ON)
- 4.4 - FADE SETTING: GRADUAL SWITCH-ON
- 4.5 - FADE SETTING: GRADUAL SWITCH-OFF
- 4.6 - SELECTION OF MINIMUM INTENSITY VALUE
- 4.7 - LOAD STATE WHEN THE CONTROL UNIT IS SWITCHED ON
- 4.8 - TIMED ON
- 4.9 - FACTORY SETTINGS, RESET CONTROL UNIT

### 5 - FURTHER DETAILS

- 5.1 - "SOFT OFF 1 HR" FUNCTION: FADE OFF

# 1 - PRODUCT FEATURES

## 1.1 TECHNICAL DATA

Power supply	110-240 Vac
Output	Max Load 2000W, dimmer 0-10V / 1-10V
N° of programmable transmitters	30
Radio frequency	433.920mhz ISM
Protection rating	IP20
Operating temperature	-20 +55 °C
Dimensions	174x46x35 mm

Picture 1.1a

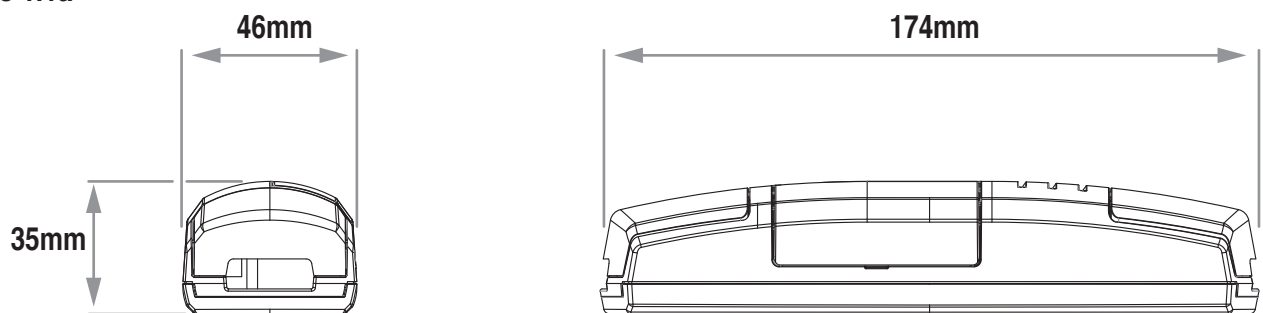

Picture 1.1b

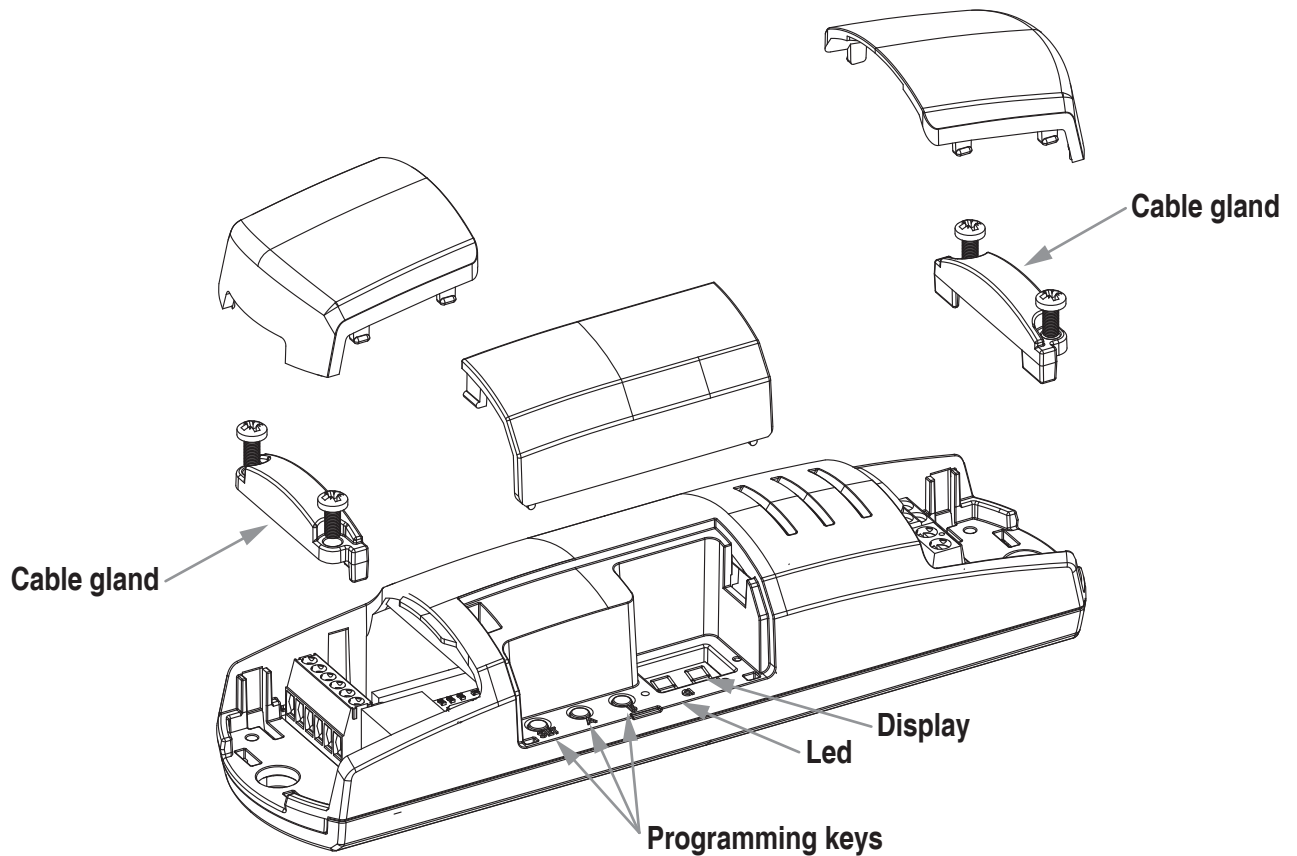

## 1.2 DESCRIPTION

Control unit with dimmer function for devices with 0-10 V or 1-10 V input such as electrical ballasts and transformers for fluorescent lamps.

The ISM (industrial, scientific and medical) radio frequency band guarantees a long range, even through walls and ceilings.

Programming via the display is quick and intuitive while its compact size mean it can be easily installed in false ceilings (picture 1.2b) and interconnection boxes (picture 1.2c).

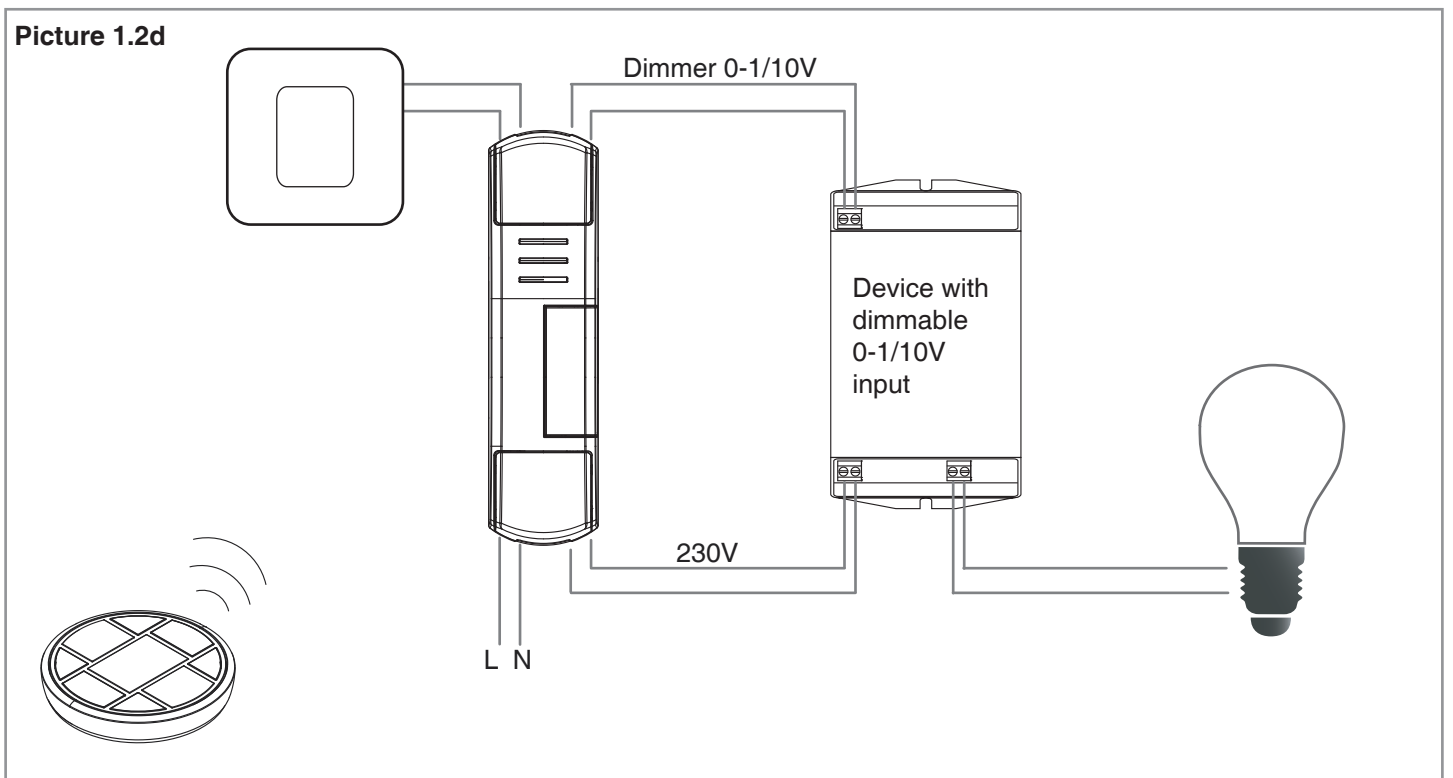
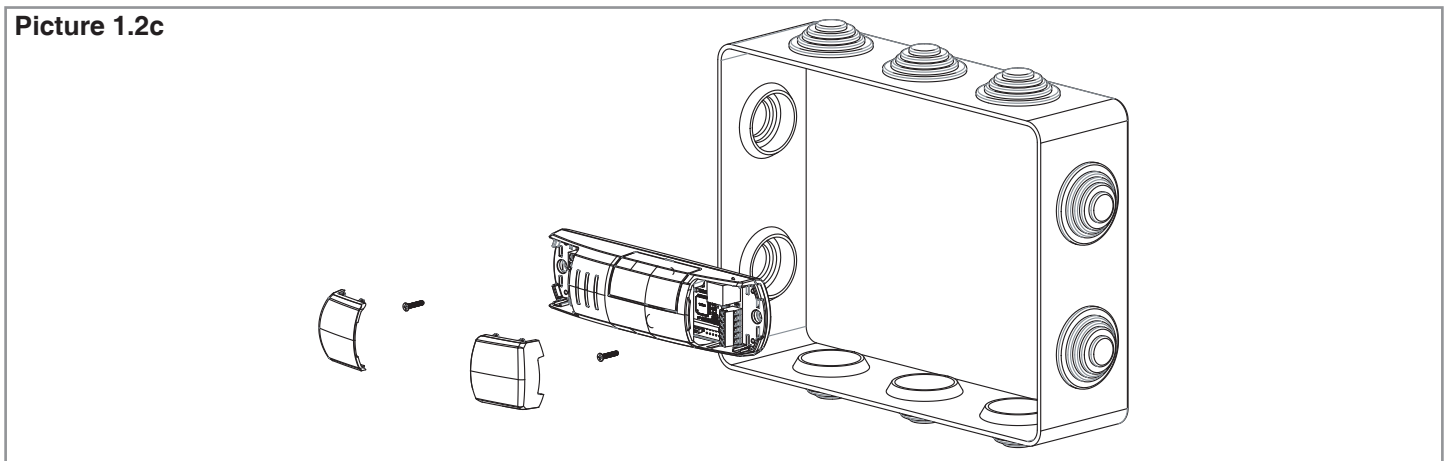
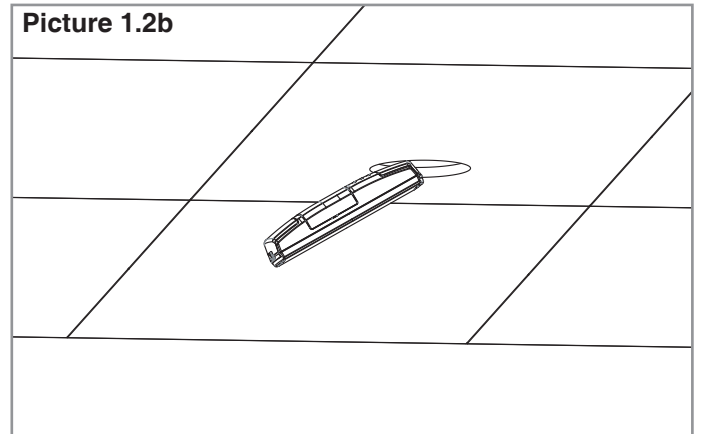
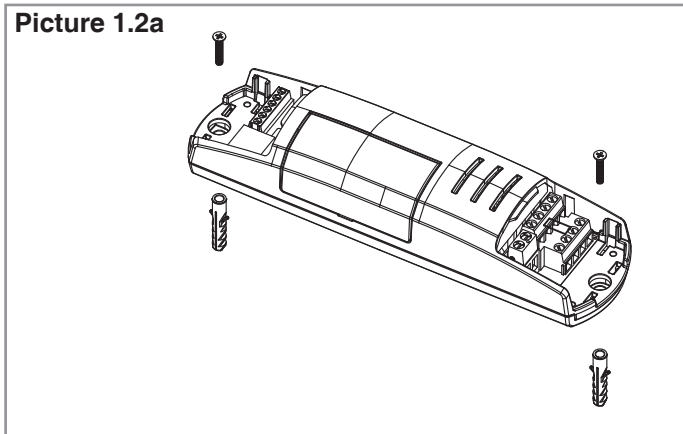

# 2 ELECTRICAL CONNECTION

## 2.1 CONNECTION DIAGRAM

Picture 2.1

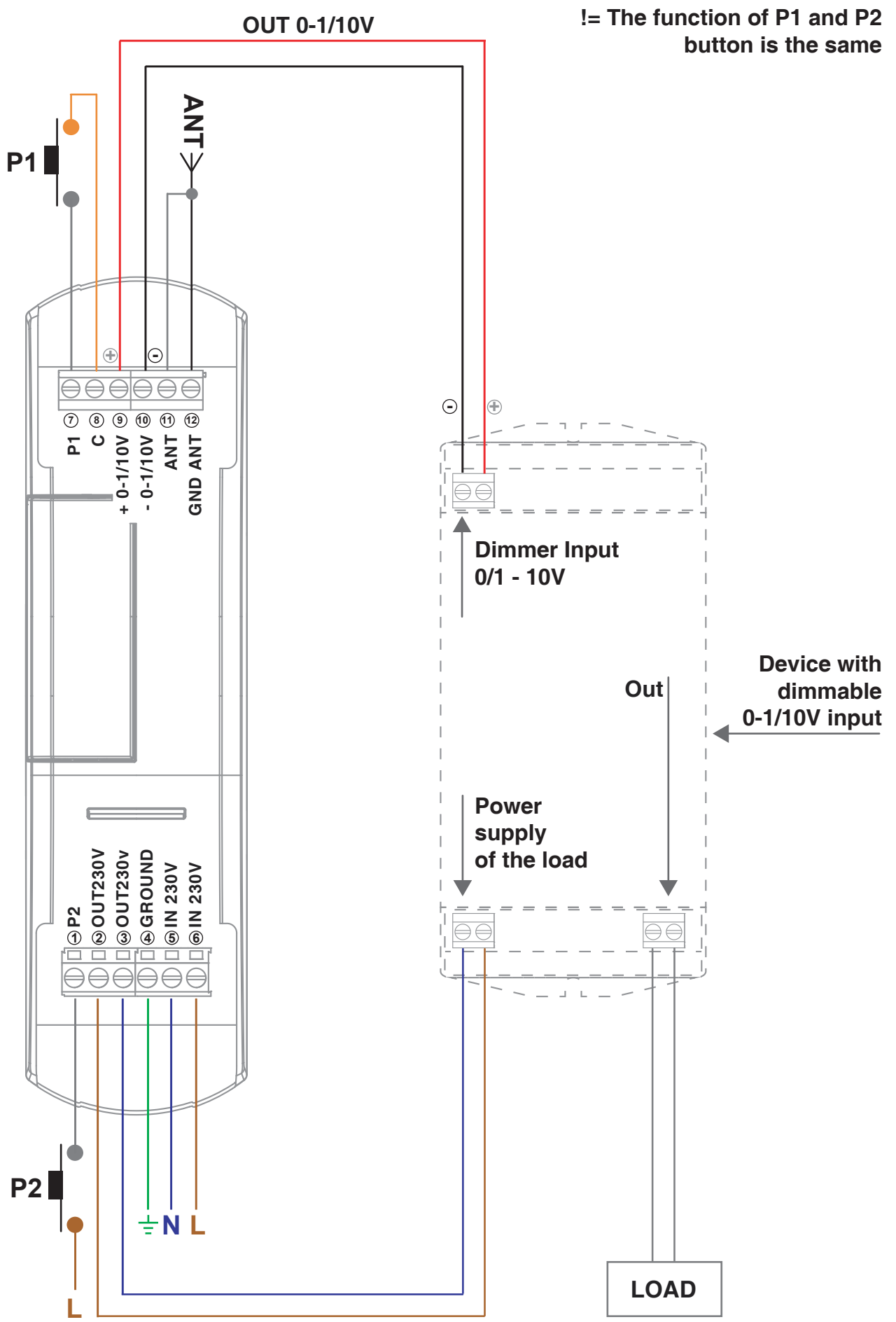

**NOTE:** multiple buttons or loads can be connected by using parallel cabling.

## 2.2 DESCRIPTION OF CONNECTIONS

Not all loads and buttons need to be connected for the control unit to operate correctly.

- Use wires with a suitable cross-section for the load connected.
- Multiple buttons can be connected by using parallel cabling.
- Multiple buttons or loads can be connected by using parallel cabling.
- The function of P1 and P2 buttons is the same. For a better connection the common of P1 is the terminal 8, the common of P2 is the phase of the system.

TERMINAL	DESCRIPTION
1	Button P2 input
2	Out 230V
3	Out 230V
4	Ground
5	Power supply 230V
6	Power supply 230V
7	Button P1 input
8	Common for button P1
9	+ out dimmer 0-1/10V
10	- out dimmer 0-1/10V
11	Aerial sleeve
12	Aerial signal

---

## 3 USE OF THE CONTROL UNIT

### 3.1 USE VIA RADIO

To control the loads via radio you must have compatible transmitters and therefore must carry out the association procedure, see paragraph 4.1.

The transmitter's control modes depend on the transmitter model used.

If the transmitter is of a generic type, its operation depends on the way it is programmed (see paragraph 4.1, table 4.1c).

If the transmitter is multifunctional, refer to the transmitter manual, to the paragraph entitled "commands sent by the transmitter", bearing in mind that it is a "dimmer" device.

---

### 3.2 USE VIA WIRE

The device is set up to accept commands via wire by button in terminals 1 and 7.

Should you want to control the load only via radio, it is not necessary to connect these devices for the control unit to work properly.

The behaviour of the different keys is shown in the following table:

	LOAD OFF	LOAD ON
INPUT P1= INPUT P2: short press	Load on	Load off
INPUT P1= INPUT P2: long press	Dimmer intensity up of load	Dimmer intensity up / Dimmer intensity down of load

## 4 CONTROL UNIT SETTINGS

In the programming zone (see picture 4) you can access the programming menu using the keys and the display. Short presses on the "SET" key let you scroll through the different programmable functions visible on the display ("P1", "P2"...). Prolonged pressure on the "SET" key (approx. 3 seconds) allows access to the menu for the function selected.

The different types of programming available are:

- "P1": programming of radio
- "P2": deletion of radio
- "P3": activation/deactivation of memory of last value
- "P4": selection of fade on
- "P5": selection of fade off
- "P6": selection of minimum intensity value
- "P8": load state when the control unit is switched on
- "P9": timed on
- "FS": factory setting, reset control unit

After 60 seconds' inactivity (no keys pressed), the control unit goes into stand-by with the displays switched off.

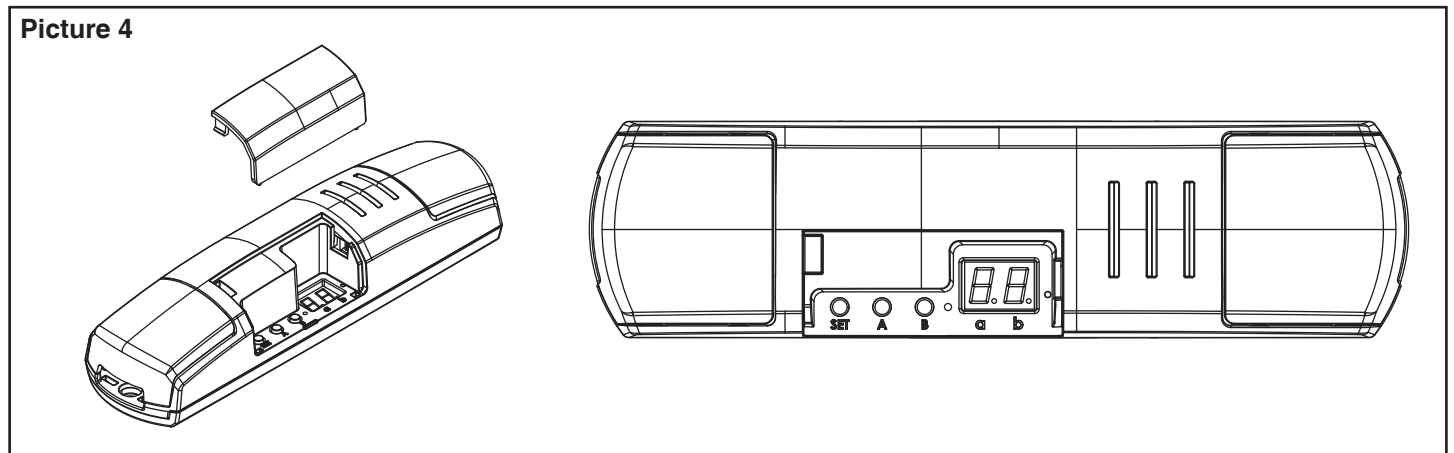

## 4.0 MENU "P0": SELEZIONE DELLA TIPOLOGIA DI CARICO COLLEGATO: "0-10V" O "1-10V"

Default: "1-10V" load set

This procedure is used to set up the dimmer type of the load. Two dimmer types are "0-10V" or "1-10V". The proper set up depends to the loads features.

### PROCEDURE:

#### STEP 1

Short presses on the "SET" key let you scroll through the menu until "P0" programming appears on the display.

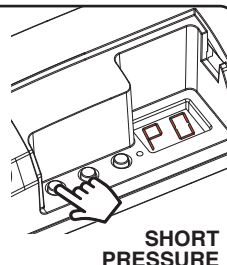

#### STEP 2

A prolonged press on the "SET" key (approx. 3 seconds) takes you into programming.

The LED on the receiver lights up

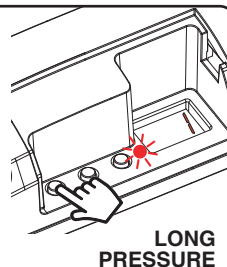

#### STEP 3

Short presses on key "B" let you choose the function you want to programme shown on the displays based on what is shown in the table alongside

DISPLAY	TYPE OF CONTROL
1	1-10V
2	0-10V

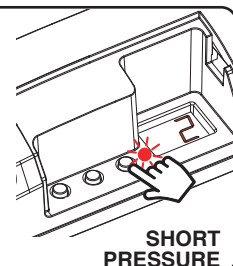

#### STEP 4

To confirm give a long press on the "SET" key (approx. 3 seconds).

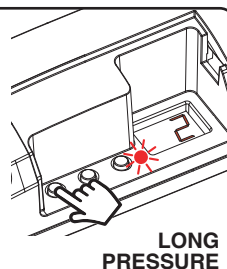

#### STEP 5

The control unit goes back to the menu displaying the different types of programming.

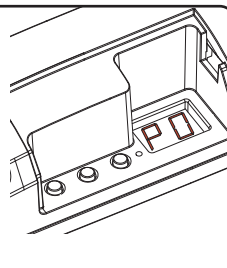

## 4.1 MENU "P1": RADIO PROGRAMMING

This procedure lets you programme compatible multifunctional or generic transmitters.

### WHICH REMOTE CONTROL DO YOU WANT TO ASSOCIATE WITH THE CONTROL UNIT?

#### MULTIFUNCTIONAL TRANSMITTERS

**CODES:**

HB70-SLCT, HB70-SPCT,  
HB80-1C, HB80-1DIM, HB80-2L, HB80-30D, HB80-30RGBW, HB80-4C, HB80-4DIM, HB80-4L,  
HB90-6LT,  
ROUND-1SP,  
SENSA-M, SENSA-P, SENSA-R35M, SENSA-R35P, SENSA-R35T, SENSA-T,  
TOUCH-1, TOUCH-1CCT, TOUCH-1DIM, TOUCH-1SP, TOUCH-1L, TOUCH-1RGBW, TOUCH-3C, TOUCH-4DIM, TOUCH-CFU

With multifunctional transmitters the transmitter control modes depend on the model used. Refer to the transmitter manual, to the paragraph entitled "commands sent by the transmitter", bearing in mind that it is an "dimmer" device.

#### GENERIC TRANSMITTERS (WIRELESS BUS)

**CODES:**

HB80-6G,  
MCU-TX4,  
TOUCH-1G, TOUCH-2G, TOUCH-4G, TOUCH-LOCK4, TOUCH-TX2,  
ROUND-1G

With generic transmitters, the transmitter's control modes depend on the function associated with the key during the association procedure.

The available function for the key are:

**TABLE 4.1 - KEY FUNCTIONS OF THE GENERIC TRANSMITTER**

NUMBER TO BE SET IN "STEP 3b" OF THE PROCEDURE	KEY FUNCTION
1	Function of pre-assigned key (see transmitter manual)
2	ON/OFF
3	ON
4	OFF
5	Dimmer UP
6	Dimmer DOWN
7	<b>Short press:</b> ON/OFF <b>Prolonged press:</b> Dimmer intensity UP/ DOWN
8	<b>Short press:</b> ON <b>Prolonged press:</b> Dimmer intensity UP
9	<b>Short press:</b> OFF <b>Prolonged press:</b> Dimmer intensity DOWN
0	"Soft Off 1 hr": gradual fading in one hour (see paragraph 5.1)



# PROCEDURE

## STEP 1

Short presses on the "SET" key let you scroll through the menu until "P1" programming appears on the display.

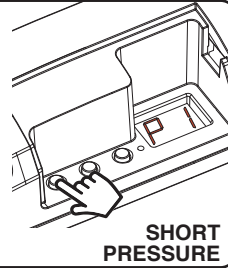

## STEP 2

A prolonged press on the "SET" key (approx. 3 seconds) takes you into programming.

The LED on the receiver comes on

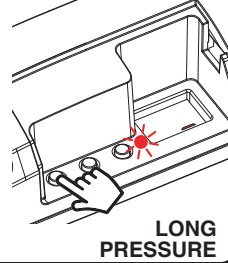

## WHICH TRANSMITTER DO YOU WANT TO PROGRAMME?

**MULTIFUNCTION TRANSMITTER**  
(see models and codes on previous page)

**GENERIC TRANSMITTER**  
(see models and codes on previous page)

## STEP 3a

Short presses on key "B" let you set value "1" on the display

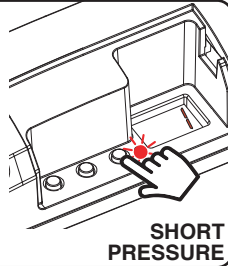

## STEP 3b

Short presses on key "B" let you choose the function you want to programme shown on the displays. See table 4.1 on the previous page.

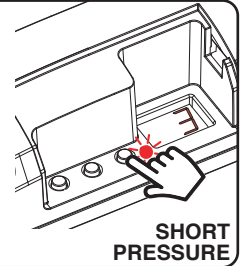

## STEP 4

Give a long press on key "B" (approx. 3 seconds).

The LED on the display comes on

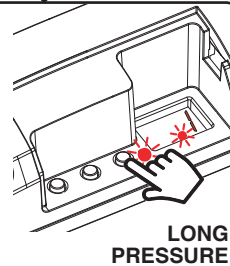

## STEP 5

Make a transmission with the transmitter to be saved (see transmitter manual, the paragraph entitled "transmitter programming").

The LED on the receiver flashes 3 times to signal that it has been received.

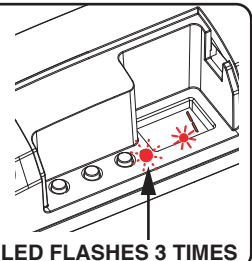

## STEP 6

The control unit listens for 50 seconds in case you want to add other transmitters. To immediately exit the procedure give a short pressure on key "b".

The LED on the display turns off

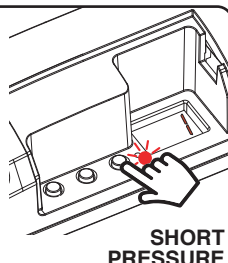

## STEP 7

The control unit goes back to the menu displaying the radio programming. If you want to save other transmitters, go back to point 3 of this procedure.

If you want to go back to the menu displaying the different types of programming, give a prolonged press to the "SET" key (approx. 3 seconds).

## 4.2 MENU "P2": DELETION OF RADIO

These procedures let you delete transmitters that have already been programmed from the receiver's memory.

### DELETION OF SINGLE TRANSMITTER CHANNEL:

#### STEP 1

Short presses on the "SET" key let you scroll through the menu until "P2" programming appears on the display.

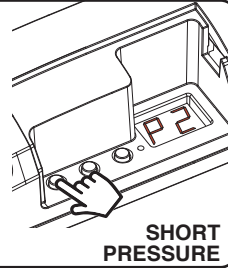

#### STEP 2

A prolonged press on the "SET" key (approx. 3 seconds) takes you into programming.

The LED on the receiver lights up

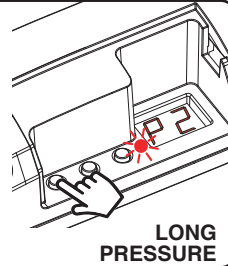

What is shown on display "a" and "b" has no influence on this procedure.

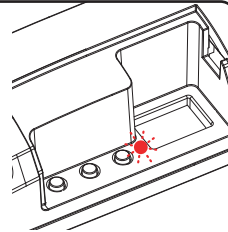

#### STEP 3

Give a long press on key "B" (approx. 3 seconds)

The LED on the receiver starts to flash

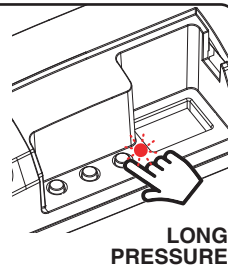

#### STEP 4

Within 5 seconds make a transmission with the remote control that you want to delete.

The LED on the receiver will flash rapidly and stay on



MAKE A TRANSMISSION WITH THE TRANSMITTER

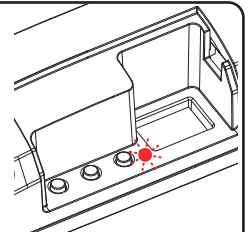

#### STEP 5

The control unit goes back to the menu displaying the radio deletion. If you want to delete other transmitters, go back to point 3 of this procedure.

If you want to go back to the menu displaying the different types of programming, give a prolonged press to the "SET" key (approx. 3 seconds).

## DELETION OF ALL THE SAVED TRANSMITTERS:

### STEP 1

Short presses on the "SET" key let you scroll through the menu until "P2" programming appears on the display.

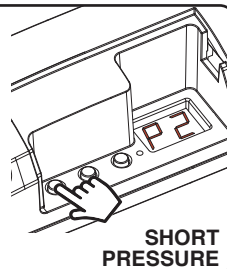

### STEP 2

A prolonged press on the "SET" key (approx. 3 seconds) takes you into programming.

The LED on the receiver lights up

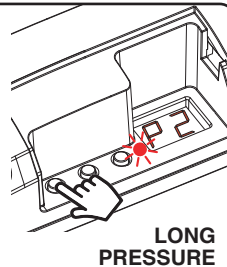

What is shown on display "a" and "b" has no influence on this procedure.

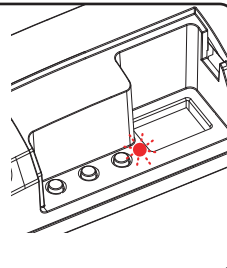

### STEP 3

Give a long press on key "B" (approx. 3 seconds)

The LED on the receiver starts to flash

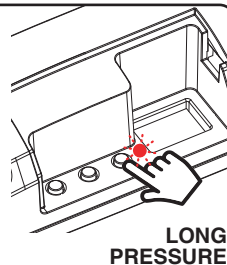

### STEP 4

Within 5 seconds quickly press key "B" to confirm the deletion.

The LED on the receiver will flash and stay on

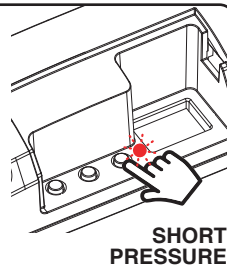

### STEP 5

The control unit goes back to the menu displaying the radio deletion. If you want to delete other transmitters, go back to point 3 of this procedure.

If you want to go back to the menu displaying the different types of programming, give a prolonged press to the "SET" key (approx. 3 seconds).

## 4.3 MENU "P3": "SAVE" FUNCTION: (BRIGHTNESS LEVEL AT SWITCH-ON)

Default: switches on with light at maximum brightness

With this procedure you can set the intensity value at which the load switches on.

### PROCEDURE:

#### STEP 1

Short presses on the "SET" key let you scroll through the menu until "P3" programming appears on the display.

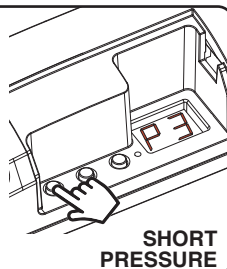

#### STEP 2

A prolonged press on the "SET" key (approx. 3 seconds) takes you into programming.

The LED on the receiver lights up

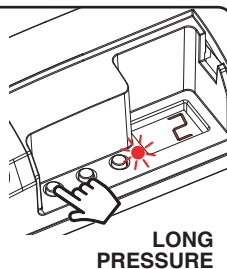

#### STEP 3

Make short presses on key "B" to choose the setting you want to set based on table alongside

DISPLAY	SAVE FUNCTION: INTENSITY AT SWITCH-ON
1	"SAVE" function on. The load will switch on at the last brightness value set before it was switched off
2	Switch-on of load at maximum intensity

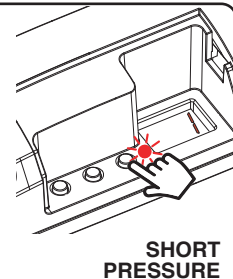

#### STEP 4

To confirm give a prolonged press on the "SET" key (approx. 3 seconds).

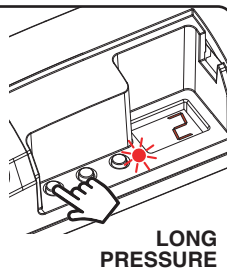

#### STEP 5

The control unit goes back to the menu displaying the different types of programming.

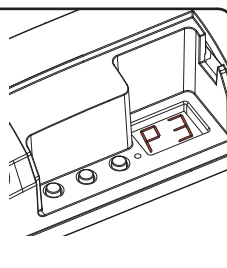

## 4.4 MENU "P4": FADE SETTING: GRADUAL SWITCH-ON

Default: switch-on in approx. 0.5

This procedure means you can set the duration of the switch-on time.

### PROCEDURE:

**STEP 1**  
Short presses on the "SET" key let you scroll through the menu until "P4" programming appears on the display.

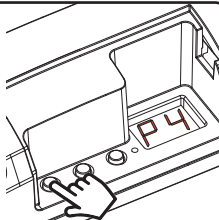

**SHORT PRESSURE**

**STEP 2**  
A prolonged press on the "SET" key (approx. 3 seconds) takes you into programming.  
The LED on the receiver lights up

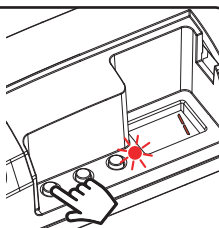

**LONG PRESSURE**

**STEP 3**  
Make short presses on key "B" to choose the setting you want to set based on table alongside

DISPLAY	FADE: FADE ON TIME
—	immediate ON
<b>01</b>	ON ~ 0,5s
<b>02</b>	ON ~ 2s
<b>03</b>	ON ~ 4s
<b>04</b>	ON ~ 10s

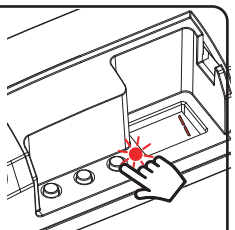

**SHORT PRESSURE**

**PASSO 4**  
To confirm give a prolonged press on the "SET" key (approx. 3 seconds).

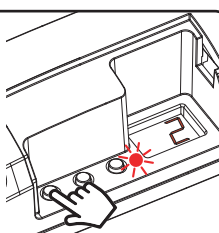

**LONG PRESSURE**

**PASSO 5**  
The control unit goes back to the menu displaying the different types of programming.

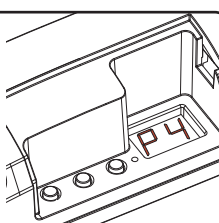

## 4.5 MENU "P5": FADE SETTING: GRADUAL SWITCH-OFF

Default: switch-off in approx. 0.5 seconds

This procedure means you can set the duration of the switch-off time.

### PROCEDURE:

**STEP 1**  
Short presses on the "SET" key let you scroll through the menu until "P5" programming appears on the display.

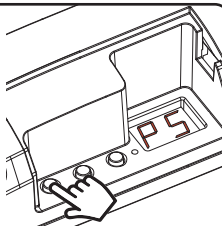

**SHORT PRESSURE**

**STEP 2**  
A prolonged press on the "SET" key (approx. 3 seconds) takes you into programming.  
The LED on the receiver lights up

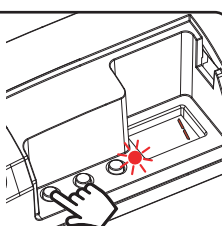

**LONG PRESSURE**

**STEP 3**  
Make short presses on key "B" to choose the setting you want to set based on table alongside

DISPLAY	FADE: FADE OFF TIME
—	immediate OFF
<b>01</b>	OFF ~ 0,5s
<b>02</b>	OFF ~ 2s
<b>03</b>	OFF ~ 4s
<b>04</b>	OFF ~ 10s

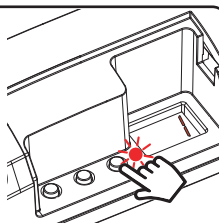

**SHORT PRESSURE**

**PASSO 4**  
To confirm give a prolonged press on the "SET" key (approx. 3 seconds).

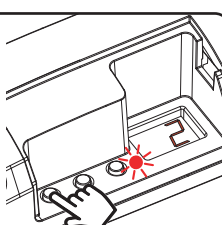

**LONG PRESSURE**

**PASSO 5**  
The control unit goes back to the menu displaying the different types of programming.

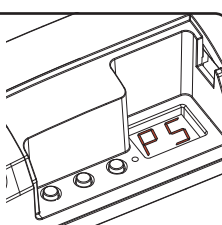

## 4.6 MENU "P6": SELECTION OF MINIMUM INTENSITY VALUE

Default: No minimum value

This procedure lets you select the minimum intensity value that can be set during normal operation.

### PROCEDURE:

**STEP 1**  
Short presses on the "SET" key let you scroll through the menu until "P6" programming appears on the display.

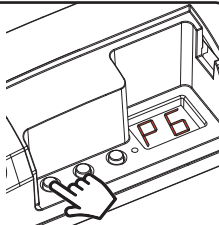

**SHORT PRESSURE**

**STEP 2**  
A prolonged press on the "SET" key (approx. 3 seconds) takes you into programming.  
The LED on the receiver lights up

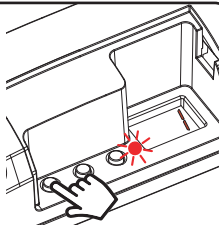

**LONG PRESSURE**

**STEP 4**  
Make short presses on key "B" to choose the setting you want to set based on table alongside

DISPLAY "b"	MINIMUM BRIGHTNESS THAT CAN BE SET
01	Default
02	Value Displayed: Set the desired minimum intensity value

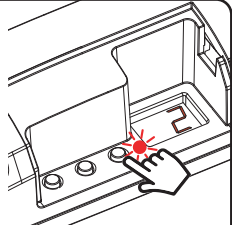

**SHORT PRESSURE**

**STEP 5**  
To confirm give a prolonged press on the "SET" key (approx. 3 seconds).

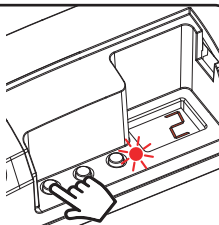

**LONG PRESSURE**

**STEP 6**  
The control unit goes back to the menu displaying the different types of programming.

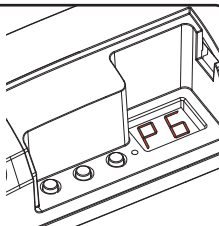

## 4.7 MENU "P8": LOAD STATE WHEN THE CONTROL UNIT IS SWITCHED ON

Default: Light Off

This process is used to set the state of Leds when the control unit is switched on (for example when the power supply is provided by a general switch or timer).

### PROCEDURE:

#### STEP 1

Short presses on the "SET" key let you scroll through the menu until "P7" programming appears on the display.

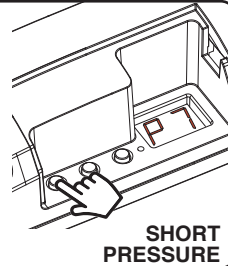

#### STEP 2

A prolonged press on the "SET" key (approx. 3 seconds) takes you into programming.

The LED on the receiver lights up

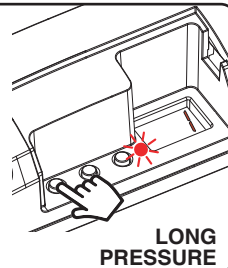

#### STEP 3

Short presses on key "B" let you choose the function you want to programme shown on the displays based on what is shown in the table alongside

DISPLAY	BRIGHTNESS AT SWITCH-ON
1	Default (light off)
2	The light switches on in the same status as the load is currently in: Set the desired status of light

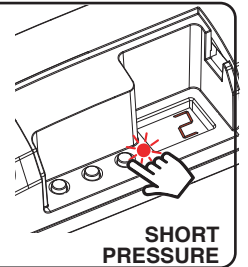

#### STEP 4

To confirm give a prolonged press on the "SET" key (approx. 3 seconds).

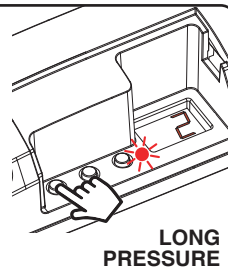

#### STEP 5

The control unit goes back to the menu displaying the different types of programming.

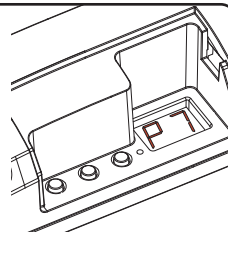



## 4.8 MENU "P9": TIMED ON

Default: No timing

This process is used to set the time for which the Leds stays on before an automatic switch off.

### PROCEDURE:

#### STEP 1

Short presses on the "SET" key let you scroll through the menu until "P8" programming appears on the display.

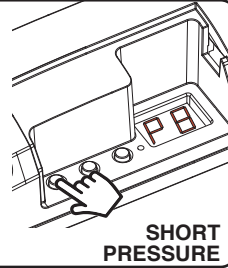

#### STEP 2

A prolonged press on the "SET" key (approx. 3 seconds) takes you into programming.

The LED on the receiver lights up

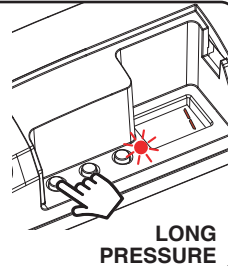

#### STEP 3

Short presses on key "B" let you choose the timing that you want to programme shown on the displays based on what is shown in table alongside

DISPLAY	TIMED ON
1	No Timing
2	1 minute
3	5 minutes
4	15 minutes
5	40 minutes
6	1 hour
7	2 hours
8	3 hours
9	8 hours

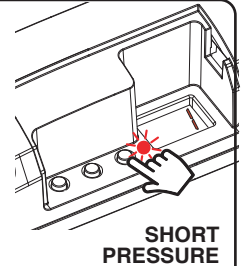

#### STEP 4

To confirm, give a prolonged press on the "SET" key (approx. 3 seconds).

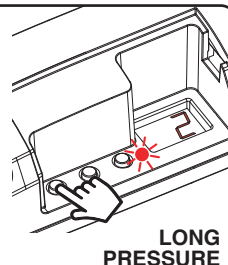

#### STEP 5

The control unit goes back to the menu displaying the different types of programming.

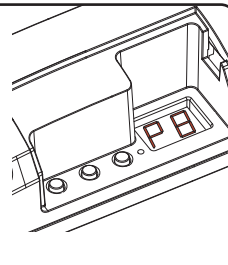

## 4.9 MENU "FS": FACTORY SETTING, RESET DELLA CENTRALE

This procedure let you take the control unit back to factory settings.

### PROCEDURE:

**STEP 1**  
Short presses on the "SET" key let you scroll through the menu until "FS" programming appears on the display.

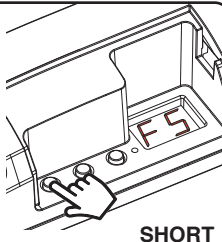

SHORT PRESSURE

**STEP 2**  
A prolonged press on the "SET" key (approx. 3 seconds) takes you into programming.  
The LED on the receiver lights up

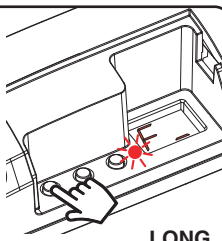

LONG PRESSURE

**STEP 3**  
Con pressioni brevi del tasto "B" posso modificare l'impostazione visualizzata sul display "b":

display = F1	reset factory parameters, but no deletion of already programmed transmitters
display = F2	full reset of factory parameters, even stored transmitters will be deleted

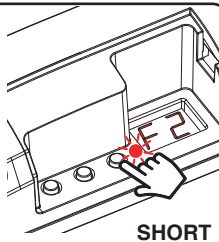

SHORT PRESSURE

**STEP 4**  
To confirm, give a prolonged press on the "SET" key (approx. 3 seconds).  
The LED flashes

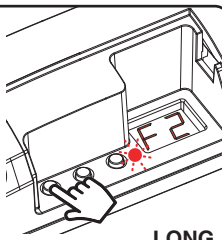

LONG PRESSURE

**STEP 5**  
The control unit goes back to the menu displaying the different types of programming.

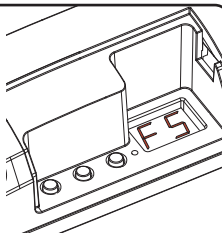

## 5 FURTHER DETAILS

The following paragraphs describe the ways the lights connected are commanded and controlled.

---

### 5.1 “SOFT OFF 1 HR” FUNCTION: FADE OFF

The "Soft off 1 hr" function is a gradual fading off in one hour starting from the colour and intensity set at the time the command was sent.

This function can be activated after adjusting the colour and intensity as desired (via radio or wire);

- VIA RADIO WITH GENERIC TRANSMITTER: with a generic transmitter programmed with the "soft off 1 hr" function.

This gradual switch-off can be interrupted at any time by the sending of another command via radio or via wire.



MNLTOP-0110ENV1.1

**Nexta Tech**

company brand of Team srl  
via G.Oberdan 90, 33074  
Fontanafredda (PN) - Italy  
Ph. +39 0434 998682  
Email: [info@nexta-tech.com](mailto:info@nexta-tech.com)  
Web: [www.nexta-tech.com](http://www.nexta-tech.com)