

# MCX-M500

NEXTA  
T E C H

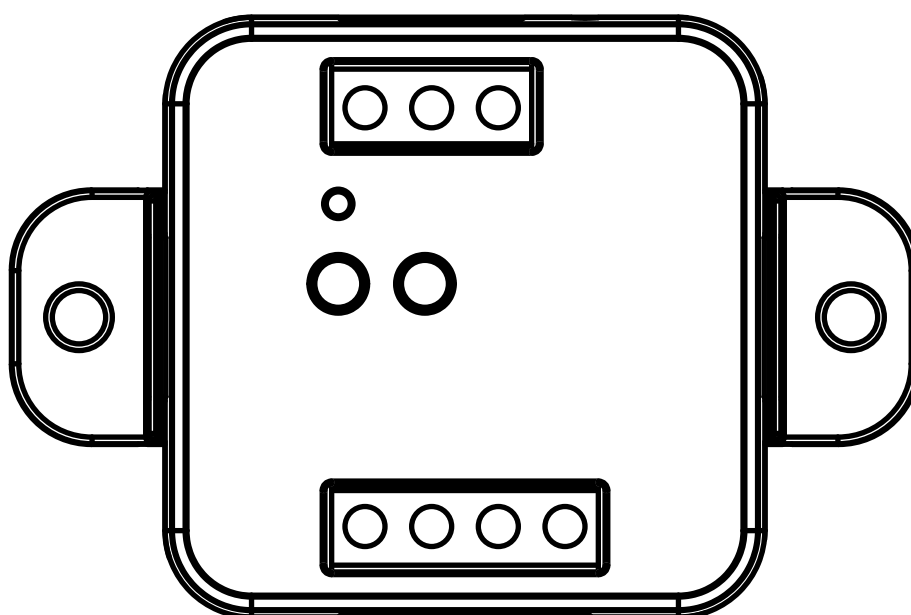

**Control unit for 230Vac motors with built-in dip switches.  
Power supply 230Vac, Max 500W.  
Integrated 433,92 MHz radio receiver.**

# INDEX

1 - PRODUCT FEATURES	
1.1 - TECHNICAL DATA	page 3
<hr/>	
2 - CONNECTION DIAGRAMS	
2.1 - CONNECTION DIAGRAM WITH NEUTRAL FROM CONTROL UNIT	page 4
2.2 - CONNECTION DIAGRAM WITH NEUTRAL FROM THE ELECTRICAL SYSTEM	page 5
<hr/>	
3 - USE OF THE CONTROL UNIT	
3.1 - TYPICAL INSTALLATION	page 6
3.2 - USE VIA WIRE	page 7
3.3 - USE VIA RADIO	page 7
<hr/>	
4 - CONTROL BY RADIOTRANSMITTERS	
4.1 - RADIOTRANSMITTER SETTING	page 8
4.2 - DELETION OF RADIOTRANSMITTERS	page 9
<hr/>	
5 - ADVANCED PROGRAMS	
5.1 - CONFIGURATION OF MANOEUVRE TIMES	page 10
5.2 - FUNCTION CUSTOMIZATION OF THE "WIRELESS BUS" TRANSMITTER BUTTONS	page 11
5.3 - WIRED INPUT SETTING	page 12
5.4 - WIRED INPUT MODE SETTING	page 13
5.5 - RESET	page 14
<hr/>	

# 1 - PRODUCT FEATURES

## 1.1 TECHNICAL DATA

Power supply (Input)	230Vac
Load type (Output)	230Vac motor with built-in limit switches
Max power load (Output)	500W
N° of programmable transmitters	30
RF receiver frequency	433,920MHz
Protection rating	IP20
Working temperature	-20° +55°
Box dimensions	52x43x21 mm

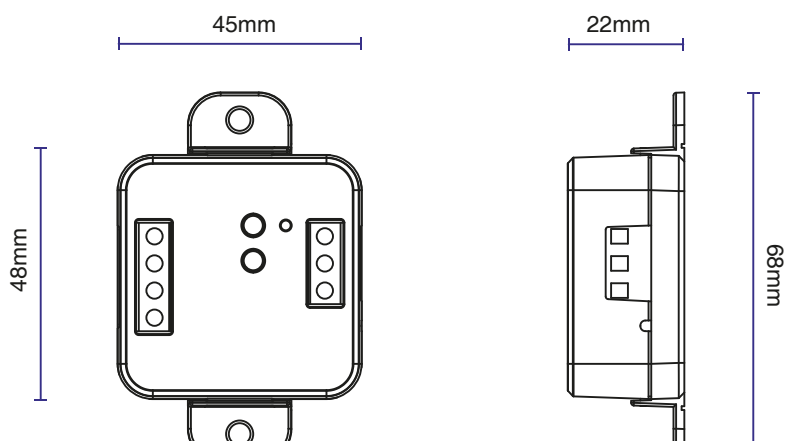
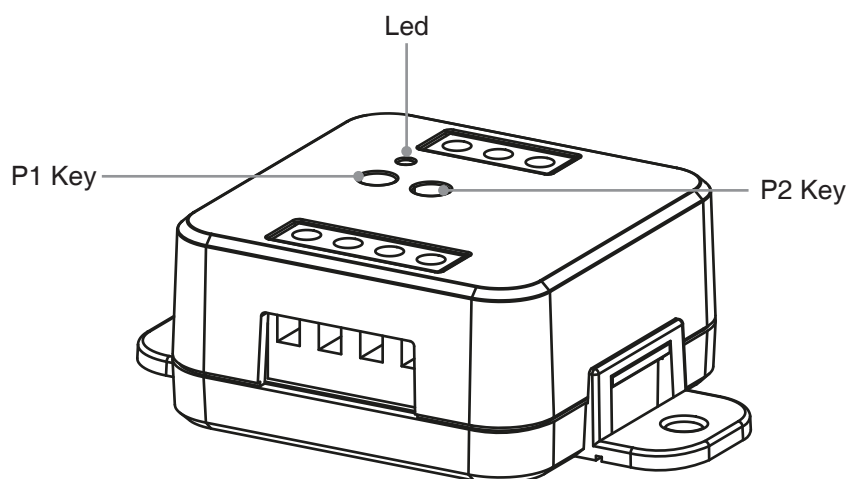

## 2 - CONNECTION DIAGRAMS

### RECOMMENDATIONS

- Installation must be carried out only by professional technicians in accordance with the applicable electrical and safety regulations.
- All connections shall be operated without electrical voltage.
- Use proper cables.
- Don't cut the antenna
- Provide in the power line with an appropriate disconnection device
- Dispose of waste materials in full compliance with local law.
- Do not exceed the specified load limits

### 2.1 CONNECTION DIAGRAM WITH NEUTRAL FROM CONTROL UNIT

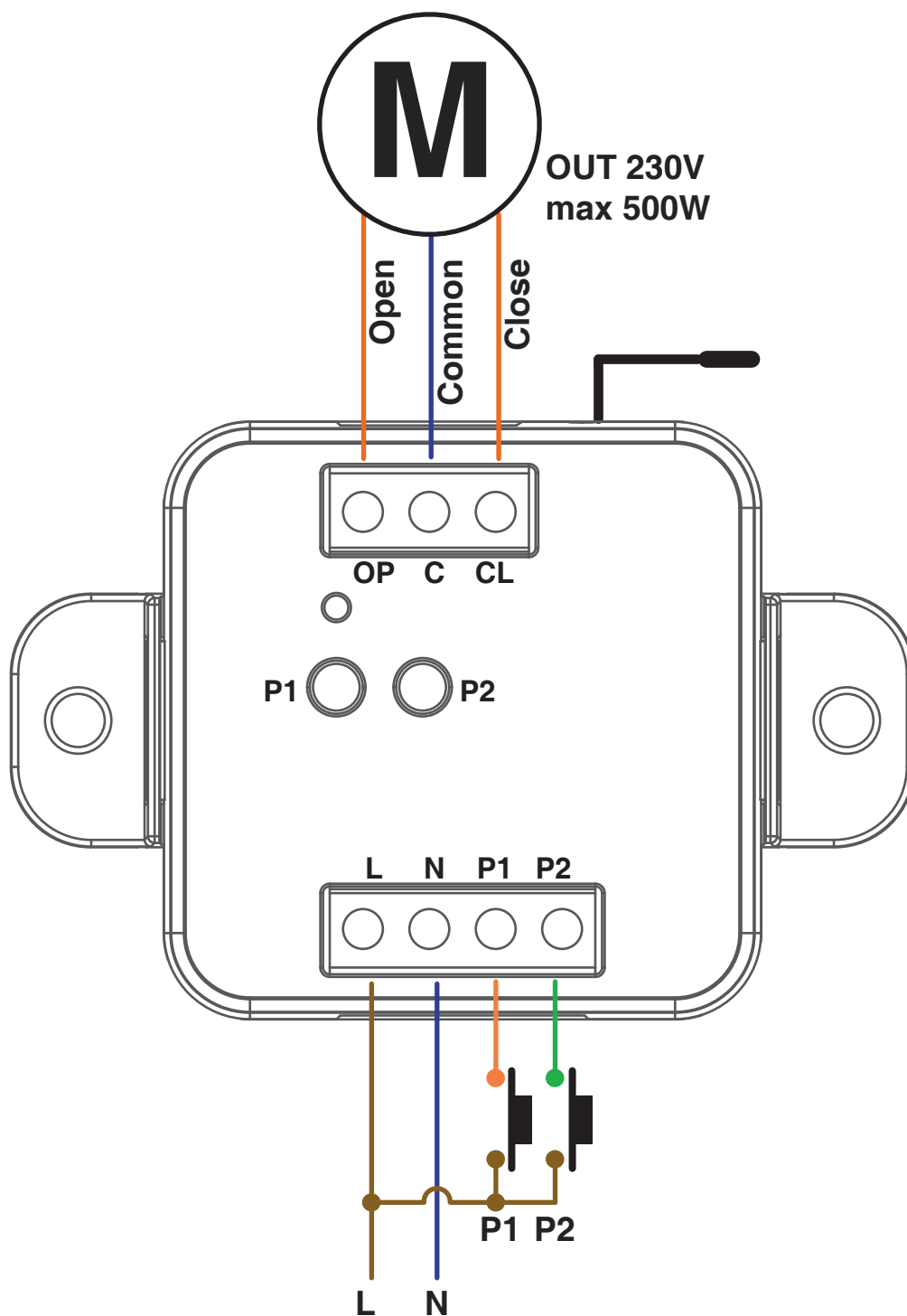

Filar inputs can be set to:

- Mono/Bi Button, see paragraph 7.3
- Automatic/man-present operation, see paragraph 7.4

## 2.2 CONNECTION DIAGRAM WITH NEUTRAL FROM THE ELECTRICAL SYSTEM

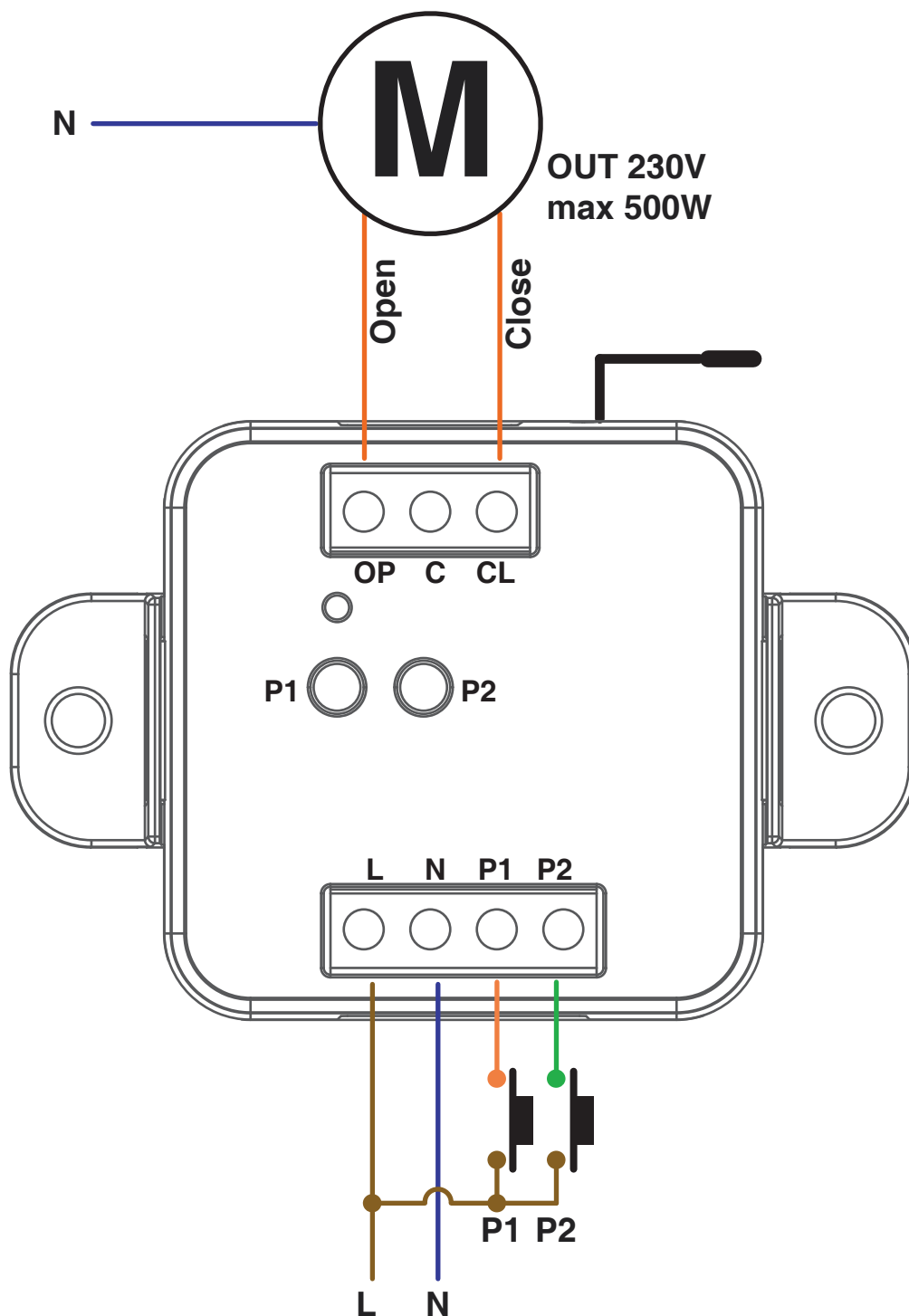

Filar inputs can be set to:

- Mono/Double Button, see paragraph 7.3
- Automatic/man-present operation, see paragraph 7.4

### 3 - USE OF THE CONTROL UNIT

#### 3.1 TYPICAL INSTALLATION

The system can be controlled by a wired push button, radio commands.  
The installation can operate with only radio controls.



#### RADIOTRANSMITTER CONFIGURATION

See paragraph 4

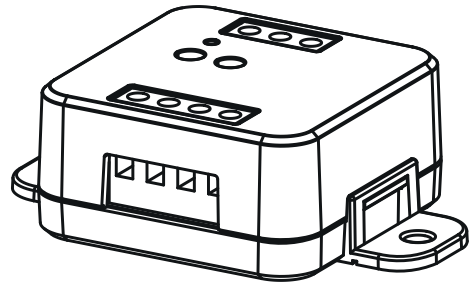

NEXTA CONTROL UNIT

### **3.2 USE VIA WIRE**

Once connected, the button is already active with Open/Stop/Close function.

### **3.3 USE VIA RADIO**

To control the load via radio you must have compatible transmitters and therefore must carry out the association procedure, see paragraph 4.

## 4 - MANAGEMENT WITH REMOTE CONTROL

This procedure lets you programme/delete compatible transmitters.

### 4.1 - RADIO PROGRAMMING

This procedure lets you programme compatible multifunctional or generic transmitters.

#### STEP 1

Press the button P1 on the receiver for a short time.  
The LED comes red on and stays on.

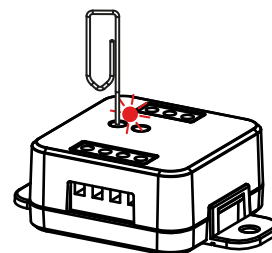

**ACTION:** Short pressure P1 button    **LED:** Turns on red

#### STEP 2

Within 60 seconds make a transmission with the transmitter to be saved.

The LED on the receiver Flashes 3 times and turns off.

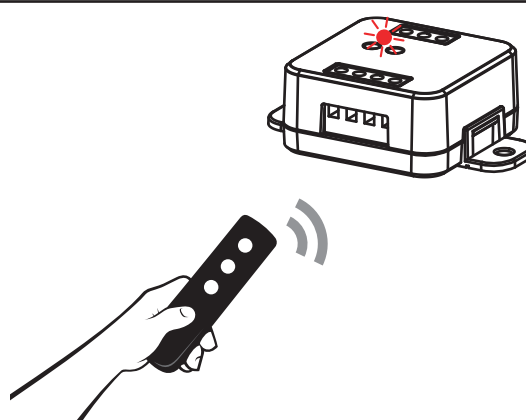

**ACTION:** Send a command with remote control    **LED:** Flashes 3 times



## 4.2 - DELETION OF REMOTE CONTROL

These procedures let you delete from the memory transmitters that have already been programmed.

### STEP 1

Hold the receiver button P1 down (about 8 seconds.) until the LED begins to Flash.

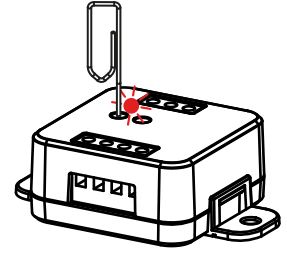

**ACTION:** Hold button P1 down    **LED:** Flashes red

**DELETION OF SINGLE  
TRANSMITTER**

**DELETION OF ALL  
TRANSMITTER SAVED**

### STEP 2a

Within 10 seconds make a transmission with the transmitter that you want to delete.  
The LED flashes quickly and turns off.

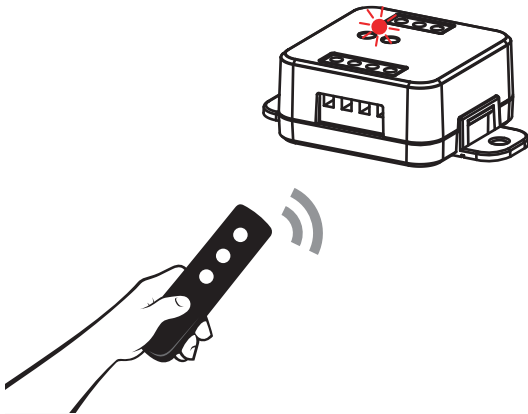

**ACTION:** Make a transmission with the transmitter  
**LED:** Flashing quickly and turns off

### STEP 2B

Within 10 seconds press the button RADIO on the receiver for a short time to confirm the deletion of all transmitters.  
The LED starts Flashing quickly and turns off.

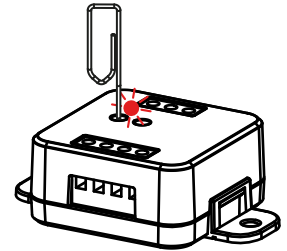

**ACTION:** Short press of button P1  
**LED:** Flashing quickly and turns off

## 5 - ADVANCED PROGRAMS

### 5.1 - CONFIGURATION OF MANEUVER TIMES

Default: 60 seconds

This procedure is used to set the opening and closing manoeuvre time (maximum time that can be set 180 seconds).

#### STEP 1

Make short pressures of the P2 button.  
Each time the LED changes colour green/yellow/magenta/  
green...  
Stop pressing when the LED is green.

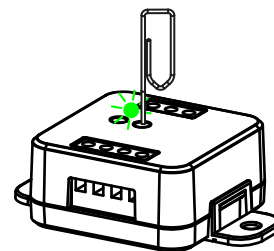

**ACTION:** make a short presses of button P2 **LED:** Turns on green/yellow/magenta/green...

#### STEP 2

Press the button P1 on the receiver for a short time and count the  
number of Flashes emitted by the LED (max 180 Flashes): each  
Flash represents a second of manoeuvre time.

Attention: the control unit Flashes one time every 1 second, example:  
120 seconds = 120 Flashes = 2 minutes of manoeuvre

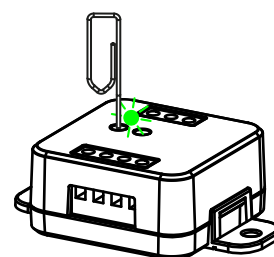

**ACTION:** Short pressure P1 button **LED:** Flash

#### STEP 3

To end the count press the button P1 for a short time during the  
Flash that corresponds to the function desired

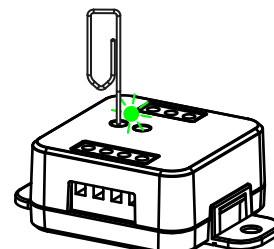

**ACTION:** Short pressure P1 button **LED:** Turns off

## 5.2 - FUNCTION CUSTOMIZATION OF THE “WIRELESS BUS” GENERIC TRANSMITTER BUTTONS

The following procedure allows you to set a custom function to the “wireless bus” family transmitter button.

### PROCEDURE

#### STEP 1

Press the button P1.  
The led turns on red.

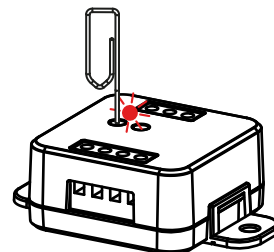

**ACTION:** Short press of button P1 **LED:** Turns on red

#### STEP 2

Press the button P2 on the receiver for a short time and count the number of Flashes emitted by the LED:

NUMBER OF FLASHES	FUNCTION
1	Open
2	Stop
3	Close
4	Open (short press) /Stop (long press)
5	Close (short press) /Stop (long press)

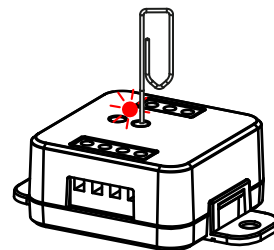

**ACTION:** Short press of button P2 **LED:** Count the number of Flashes

#### STEP 3

Press the button P2 for a short time during the Flash that corresponds to the function desired to end the count.  
The led stop Flashes and lights up steadily.

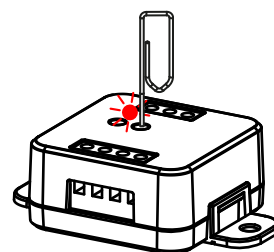

**ACTION:** Short pressure of button P2 during the Flash **LED:** Stop Flashes

#### STEP 4

Make a transmission with the transmitter to be saved  
(see transmitter manual, paragraph entitled “transmitter programming”).  
The LED on the receiver Flashes 3 times and turns off.

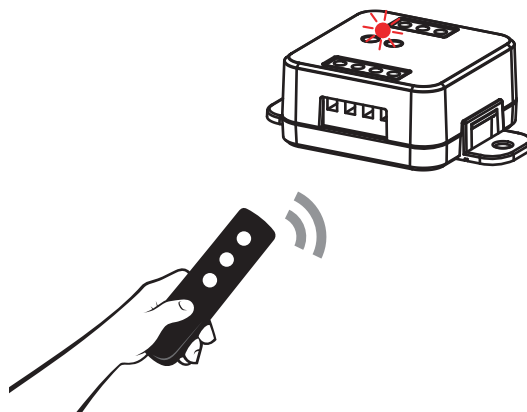

**ACTION:** Make a transmission with the transmitter **LED:** Flashes 3 times

### 5.3 - WIRED INPUT SETTING

Default: Mono button

This procedure lets you select the function of inputs "P1" (terminal 3) and "P2" (terminal 4). **WARNING:** the connected devices must be buttons.

#### PROCEDURE

##### STEP 1

Make short pressures of the P2 button.  
Each time the LED changes color: green/yellow/magenta/green...  
Release the key when the led is yellow

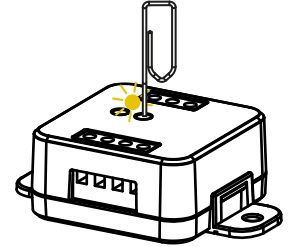

**ACTION:** Short presses of buttons P2 **LED:** green/yellow/magenta/green...

##### STEP 2

Press the button P1 on the receiver for a short time and count the number of Flashes emitted by the LED:

NUMBER OF FLASHES	FUNCTION
3	Mono Button: P1= Open/Stop/Close
6	Double button P1= Open/Stop P2= Close/Stop

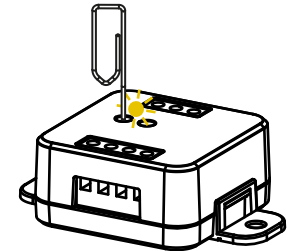

**ACTION:** Short pressure P1 button **LED:** Flash

##### STEP 3

To change the setting, repeat the procedure from point 1; the control unit will alternate between 3 and 6 Flashes.

## 5.4 - WIRED INPUT MODE SETTING

Default: automatic

This procedure allows you to select the mode of operation between:

automatic: after pressing the button the automation completes the movement to the limit switch

present man: automation moves until the button is pressed

### PROCEDURE

#### STEP 1

Make short pressures of the P2 button.

Each time the LED changes colour green/yellow/magenta/green...

Release the key when the led is magenta

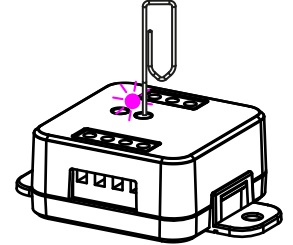

**ACTION:** Short presses of button P2 **LED:** green/yellow/magenta/green...

#### STEP 2

Press the button P1 on the receiver for a short time and count the number of Flashes emitted by the LED:

NUMBER OF FLASHES	FUNCTION
3	Automatic
6	Present man

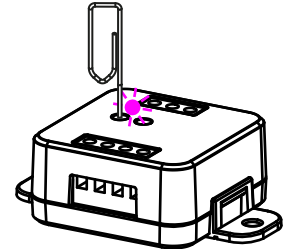

**ACTION:** Short pressure P1 button **LED:** Flash

#### STEP 3

To change the setting, repeat the procedure from point 1; the control unit will alternate between 3 and 6 Flashes.

## 5.5 - RESET OF THE CONTROL UNIT

This procedure let you take the control unit back to factory settings.

### PROCEDURE

#### STEP 1

Hold the receiver button P1 down (about 4 seconds.) until the LED begins to Flash red.

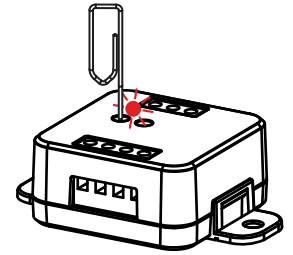

**ACTION:** Hold button P1 down    **LED:** Flashes red



#### STEP 2

Within 10 seconds, make a short press of P2 button.  
The LED 1 Flashes quickly and turns off.

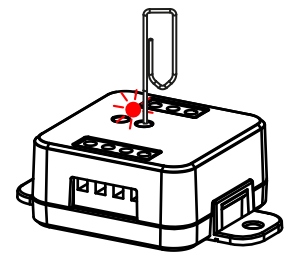

**ACTION:** Short press of P2 button    **LED:** The led Flash quickly and turns off











V1.1

**Nexta Tech**  
company brand of Team srl  
via G.Oberdan 90, 33074  
Fontanafredda (PN) - Italy  
Ph. +39 0434 998682  
Email: [info@nexta-tech.com](mailto:info@nexta-tech.com)  
Web: [www.nexta-tech.com](http://www.nexta-tech.com)